



MAHAGROUP

C_RGA 7.5 | 8.5 UC

Mobile Column Lift

Extract from the Original Operating Instructions

BA492501_101-en

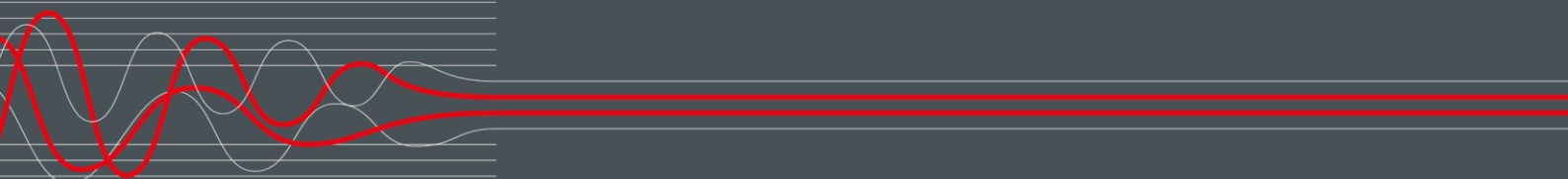

BA492501_101-en
2023-11-15a

© MAHA Maschinenbau Haldenwang GmbH & Co. KG

The reproduction, distribution and utilisation of this document as well as the communication of its contents to others without explicit authorisation is prohibited. Offenders will be held liable for the payment of damages. All rights reserved in the event of the grant of a patent, utility model or design.

The contents have been checked with great care; however, errors cannot be fully excluded. Illustrations are examples and may differ from the original product. Subject to technical change without notice.

Manufacturer

MAHA Maschinenbau Haldenwang GmbH & Co. KG
Hoyen 20
87490 Haldenwang
Germany

Phone: +49 8374 585-0
Fax: +49 8374 585-590
Mail: maha@maha.de
Web: www.maha.de

Service

MAHA SERVICE CENTER
Maybachstraße 8
87437 Kempten
Germany

Phone: +49 8374 585-100
Fax: +49 8374 585-491
Mail: service@maha.de
Web: www.mahaservicecenter.de

This document is only an excerpt from the original operating instructions.
After receipt of the delivery, the complete version of the original operating instructions must be downloaded from the MAHA website or a printout requested from MAHA.

Contents

1	General Safety Instructions	5
1.1	Introduction	5
1.2	Symbols and Signal Words	5
1.2.1	Personal Injury	5
1.2.2	Property Damage	5
1.3	What to Do in the Event of Defects or Malfunctions	6
1.4	What to Do in the Event of an Accident	6
1.5	Requirements for the Operating Personnel	6
1.6	Requirements on Service Personnel	6
1.7	Intended Use	7
1.8	Inappropriate Use	7
2	Transport, Handling and Storage	8
2.1	Safety Instructions	8
2.2	Scope of Delivery	8
2.3	Packaging Information	8
2.3.1	Dimensions and Weight	8
2.3.2	Centre of Gravity of the Packaged Lift	8
2.4	Transport and Handling	9
2.4.1	Transport and Handling of the Lifting Columns	9
2.4.2	Transport and Handling of the Lithium-Ion Batteries	10
2.5	Storage	11
2.5.1	Storage of Lifting Columns	11
2.5.2	Storage and Fire Protection of Lithium-Ion Batteries	11
3	Operation	12
3.1	Positioning the Lifting Columns	13
3.2	Adjusting the Vehicle Support	14
3.3	Picking up a Vehicle	15
3.4	Controls and Indicators	16
3.5	Switching on	17
3.6	Login Process (Pairing)	17
3.6.1	Login Lifting Column	17
3.6.2	Connect Lifting Columns to Form a Network	17
3.6.3	Cancel Login Process	18
3.6.4	Error in a Column during Pairing	18
3.7	Lifting and Lowering	18
3.7.1	Driving up to an Obstacle	18
3.7.2	CE Stop	18
3.8	Radio Standby	19
3.9	ALL Operating Mode	19
3.10	SINGLE Operating Mode	19
3.11	GROUP Operating Mode	20
3.12	Fast Travel (SPEED)	21
3.13	Switch off / Open Network	21

3.14	Radio Communication	21
3.15	Search New Radio Channel	22
3.15.1	Communication Error (Radio or Cable Error)	23
3.15.2	Overview: Status of the Lifting Column Lamps	23
3.16	Cable Emergency Operation	24
3.16.1	Activate Cable Emergency Operation	24
3.16.2	End Cable Emergency Operation	24
3.17	Output Software Version Identifier	24
3.18	Charge Battery	25
4	Troubleshooting	26
4.1	Diagnostics	26
4.2	Error Codes	26
5	CE Declaration of Conformity	27

1 General Safety Instructions

1.1 Introduction

- These operating instructions must be read carefully and understood before work commences.
- Please observe the specific safety information provided for the respective sections of the operating instructions.
- Adhering to the procedures, sequences and corresponding safety instructions is essential.
- A printed copy of the operating instructions must always be kept by the lift.
- The relevant regulations regarding accident prevention and health and safety must be observed.

1.2 Symbols and Signal Words

1.2.1 Personal Injury



DANGER

indicates an immediate hazard which, if not avoided, will result in death or severe personal injury.



WARNING

indicates a potential hazard which, if not avoided, could result in death or severe personal injury.



CAUTION

indicates a potential hazard which, if not avoided, could result in moderate or minor personal injury.

1.2.2 Property Damage

NOTICE

indicates a potentially harmful situation which, if not avoided, could result in damage to the equipment or surrounding objects.

1.3 What to Do in the Event of Defects or Malfunctions

- If a malfunction occurs, e.g. uncontrolled raising and lowering or in the case of load-bearing components of the structure becoming deformed, immediately lower the lift to the ground to its initial position or support the structure.
- Turn off the main switch and secure against unauthorised use.
- Contact service team.

1.4 What to Do in the Event of an Accident

- Notify first aiders, the ambulance service and/or immediate care doctor:
 - Where did the accident happen (address, workshop, ...)?
 - What happened?
 - How many are injured?
 - What injuries have occurred?
 - Who is reporting the accident?
- Keep calm and answer questions.

1.5 Requirements for the Operating Personnel

All persons involved in the operation of the equipment must:

- be 18 years of age or older,
- have the mental and physical capacity for their role,
- be demonstrably trained and instructed in writing in the operation of the equipment,
- have read and understood the operating instructions, and in particular the instructions on the procedure in the event of a malfunction,
- show knowledge and experience in handling the equipment and the dangers posed,
- have had certified training regarding safety regulations.

1.6 Requirements on Service Personnel

Persons who are entrusted with the installation, maintenance and/or dismantling of the equipment must in addition:

- be demonstrably trained and instructed in the required work,
- can provide evidence of appropriate qualification for work on the electrical system of the equipment (e.g. as a qualified electrician),
- be able to demonstrate expertise for vehicle lifts. This includes sufficient knowledge in the field of lifts and the relevant statutory occupational health and safety regulations, accident prevention regulations and generally accepted rules of technology to be able to assess the safe working condition

of the lift to be tested.

Qualified persons shall not only consider the current condition of the lift during the inspection. They must also be able to estimate how the lift and its structural parts will behave under operational conditions in the sequence and how wear, aging and the like will affect the safety of the lift.

1.7 Intended Use

- This lift in the version with wheel forks is intended exclusively for the safe lifting and lowering of passenger cars and commercial vehicles as part of service and repair work. For lifting other vehicles and loads, suitable load handling attachments on lifting columns with flanged carriages must be used for this purpose.
- The permissible load according to the type plate must not be exceeded.
- Only vehicles which are suitable for the lifting equipment due to their shape and the positioning of their lifting points may be lifted.
- The lift may only be operated in the temperature range 5...40 °C at a maximum humidity of 50% (at 40 °C).
- The lift must be protected from direct weather influences at all times, e.g. by using the supplied transport protection hood.
- At wind speeds above 6 m/s, operation outside enclosed spaces must be stopped and the load lowered.
- The lift may only be operated on level and sufficiently load-bearing ground; ground inclination max. 1°.
- The lift may not be modified without express written permission from the manufacturer. Non-compliance invalidates the declaration of conformity.

1.8 Inappropriate Use

- Lifting vehicles and loads with load handling attachments not approved for this purpose is not permitted.
- Passenger transport, in particular the riding of persons with the load, is not permitted.
- Lifting the load with an additional hoist is prohibited.
- The lift must not be operated in potentially explosive and flammable operation rooms or in damp rooms (e.g. washing facilities).

2 Transport, Handling and Storage

2.1 Safety Instructions



WARNING

- Wear personal protective equipment.
 - Standing under a suspended load is prohibited.
 - Before removing the packaging straps, secure the packages against falling and maintain a safe distance. Rebounding packaging straps can cause injuries!
 - Only use lifting equipment and slings that are suitable in terms of type and permitted load capacity.
 - Always ensure that the parts to be transported are suspended or loaded properly and in a fall-proof manner, taking into account their size, weight and centre of gravity. Observe transport regulations.
-

2.2 Scope of Delivery

The lifting columns are delivered upright, either lashed together or individually packed on pallets, depending on the number of pieces and destination.
Content in each case:

- 1 mobile single column with 1 lithium-ion battery
- 1 NFC tag for pairing the lifting columns
- 1 hydraulic trolley
- Operating instructions and other documents
- Transport packaging
- Optional accessories, if applicable

The number of delivered packages and contents must be checked for damage and completeness according to the order confirmation. Any transport damage must be documented immediately and reported to the delivery carrier.

2.3 Packaging Information

Packaging waste must be disposed of in accordance with applicable environmental regulations.

2.3.1 Dimensions and Weight

Dimensions (L x W x H)..... 1280 x 1200 x 2620 mm
Weight approx. 550 kg
(Data valid for pallet packaging)

2.3.2 Centre of Gravity of the Packaged Lift

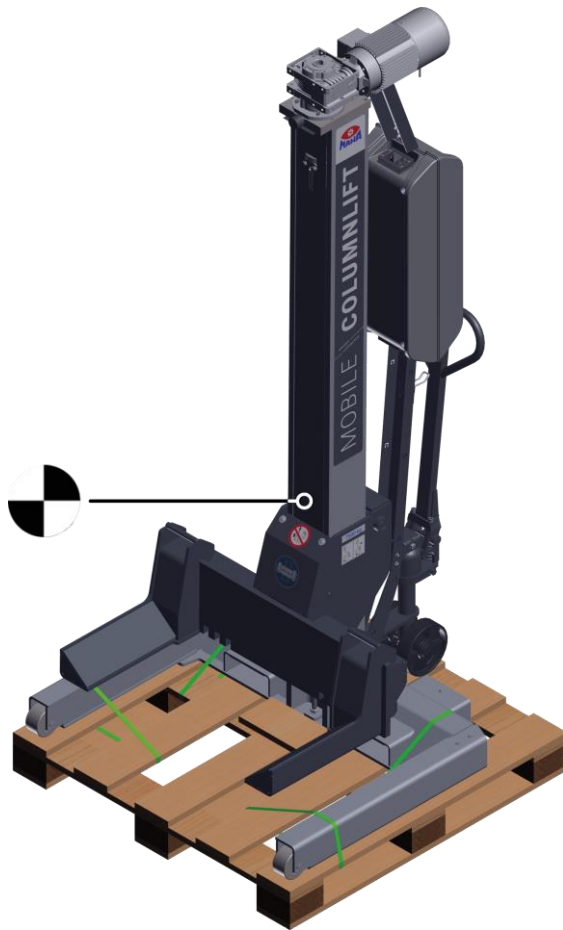

2.4 Transport and Handling

2.4.1 Transport and Handling of the Lifting Columns

To transport the lifting columns, never lift them by the lifting carriage, but by the pallet or by the forklift pockets. For this purpose, the lifting carriage should be approx. 150 mm above the lower end position.

As an alternative to transport by forklift, the eyebolt on the top plate of the lifting column can also be used, e.g. for crane transport of individual columns. The eyebolt must be screwed in tightly.



Transport via forklift pockets ▲

Eyebolt for crane transport ►

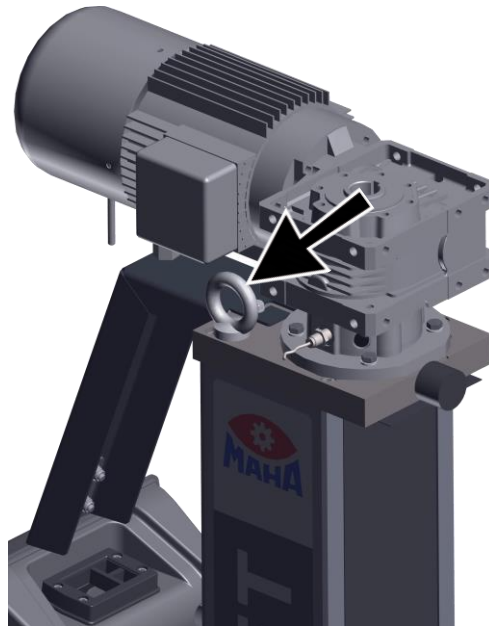

2.4.2 Transport and Handling of the Lithium-Ion Batteries





The lithium-ion battery is mounted in the operating housing of the lifting column at the factory, securely fastened by means of a strap, and wired ready for operation. On delivery, there is a transparent plastic cover over the lifting column or over the operating housing as protection against transport damage and moisture.

In principle, when transporting and handling lithium-ion batteries, strong shocks, impacts (mechanical damage), moisture (rain) and direct sunlight must be avoided, and measures must be taken to ensure safe transport (load securing).

Lithium-ion batteries are assigned the following UN numbers (identification numbers for hazardous substances) during transport:

- UN 3480 – Li-Ion battery not in equipment (devices), as spare part
- UN 3481 – Li-Ion battery packed in or with equipment (devices)

The following marking is applied ex works for the modes of transport road/rail/sea freight/air freight:

Shipping	Packing	Labelling	Position of labels
As spare part	Single packaging in carton	  	On the cardboard
In the operating housing of the lifting column	Transparent plastic cover over lifting column/ operating housing	 	On the plastic hood

2.5 Storage

2.5.1 Storage of Lifting Columns

The lifting columns must be stored in a covered place protected from direct sunlight. The storage has to take place at a constant air humidity and a temperature between 0 °C and +40 °C. The lifting columns must not be stacked.

2.5.2 Storage and Fire Protection of Lithium-Ion Batteries

For the storage/provision and fire protection of lithium-ion batteries, the relevant national specifications and guidelines as well as the specifications of the fire department and insurers must be observed. Please contact your fire department and/or building insurer in a timely manner.

Storage must be in a well-ventilated, cool place. Safety distance to combustible material min. 2 m.

For the sake of service life, lithium-ion batteries must always be stored in a dry place and within the specified temperature range. In case of longer storage, the state of charge should be checked at intervals of 3..4 months and recharged if necessary.

Only lithium-ion batteries that are in technically perfect condition (no damage, deformation, etc.) may be installed.

3

Operation



WARNING

- Observe the detailed operating instructions.
- Comply with legal accident prevention regulations.
- Wear personal protective equipment.
- Carry out visual and operational checks daily before the commencement of work (see also section “Inspection and Maintenance Plan”).
- Defects must be documented immediately and reported to customer service.
- The permissible load capacity according to the type plate must not be exceeded.
- Only vehicles suitable for the lifting equipment due to their shape and the positioning of their pick-up points may be lifted.
- The wheel forks must be adjusted so that in the event of a tire blowout, the vehicle cannot fall off the lift.
- Operation of the lift is only permissible with mounted and intact protective covers and safety devices.
- Never touch moving parts.
- Never use additional lifting gear for an already raised load.
- Maintain a safe distance from the vehicle and lift in all directions.
- Keep the working area of the load and the lift clear of obstacles. Use a guide if visibility is restricted.
- Vehicle doors must be closed during lifting and lowering.
- The transport of passengers is prohibited.
- Climbing up the lifted vehicle or the lift is prohibited.
- There must not be any people or objects within the safety zone of the lift and the load during the lifting and lowering process.
- Monitor the load and the lift during lifting and lowering. In the event of irregularities, stop the movement immediately or actuate one of the emergency stop switches.
- There is a risk of tripping on floor-mounted load handling attachments.
- Parts must not be placed on the lift or the vehicle to be lifted.
- Keep the lift and the working area clean. **ATTENTION:** Risk of slipping on oily surfaces!
- Protect all parts of the electrical system from moisture.
- Be careful when running vehicle engines. **ATTENTION:** Risk of poisoning!
- Changes to or overriding of the safety features installed is prohibited!
- Structural modifications are generally prohibited and will result in the withdrawal of the operating permit.

- Inching mode should be avoided to prevent the motor from overheating. Instead, drive briskly through.
 - During work breaks and at the end of the working day, the system must be switched off and secured against unauthorised use.
-

3.1 Positioning the Lifting Columns



Finger grip on the drawbar of the hydraulic trolley

The lifting columns can be moved and positioned on level, smooth ground by means of a hydraulic trolley with drawbar. The hydraulic trolley with drawbar works like a pallet truck.

The finger grip has three possible positions (see figure):

- To lift, move the finger grip to the lower position and pump with the drawbar to the desired height.
- To lower, pull the finger grip upwards.



CAUTION

When lowering, make sure no body parts or objects are under the lifting column!

- To move the lifting column, move the finger grip to the centre position.

3.2 Adjusting the Vehicle Support



WARNING

Avoid uneven load distribution. Danger of tipping! After adjustment, replace and secure the hinged cotter pin.

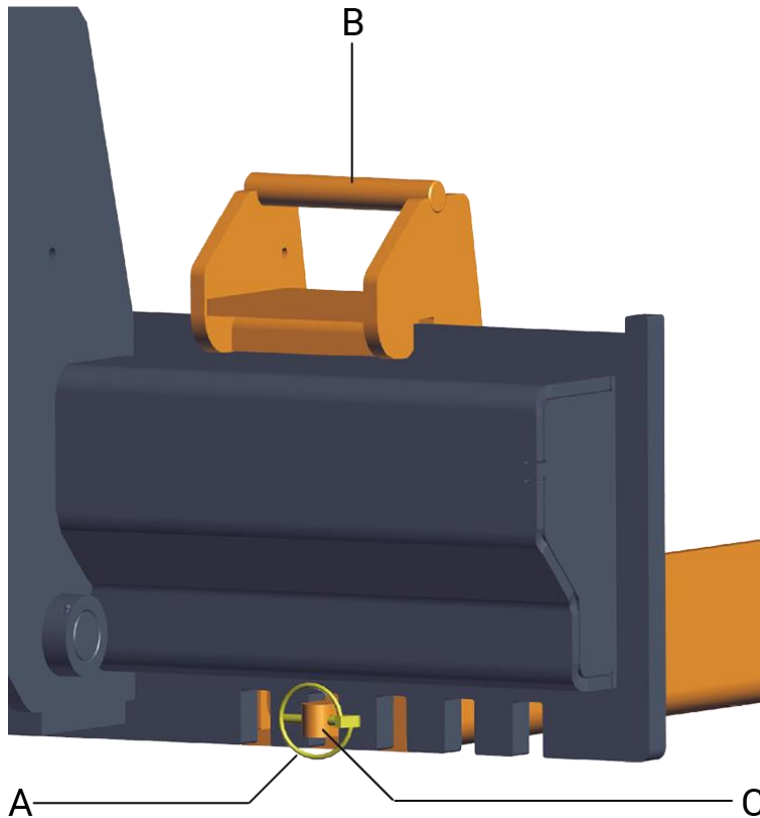

- 1 Pull off the hinged cotter pin (A) for unlocking.
- 2 Tilt the wheel fork at the handle (B) and front end and position it in the desired notch using the locking pin (C).
- 3 Secure again with hinged cotter pin. Check the secure fit of the wheel forks.
- 4 Repeat the procedure for the second wheel fork. The wheel forks must always be positioned symmetrically to the lifting column to ensure even load distribution!

When using wheel forks, their clear width can be adjusted.

To prevent the wheel from falling through in the event of a tyre blowout, the rim diameter (a) must always be clearly larger than the clear fork width (b) (see Fig.)!

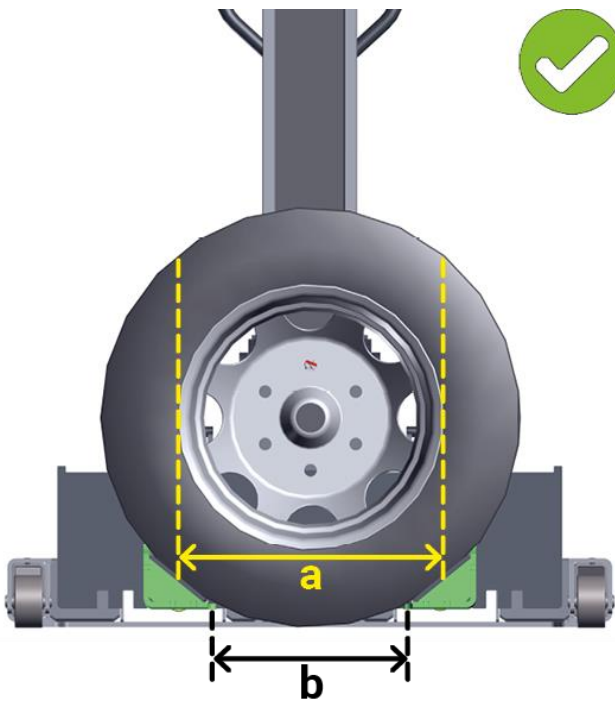

Wheel forks correctly adjusted: $a > b$

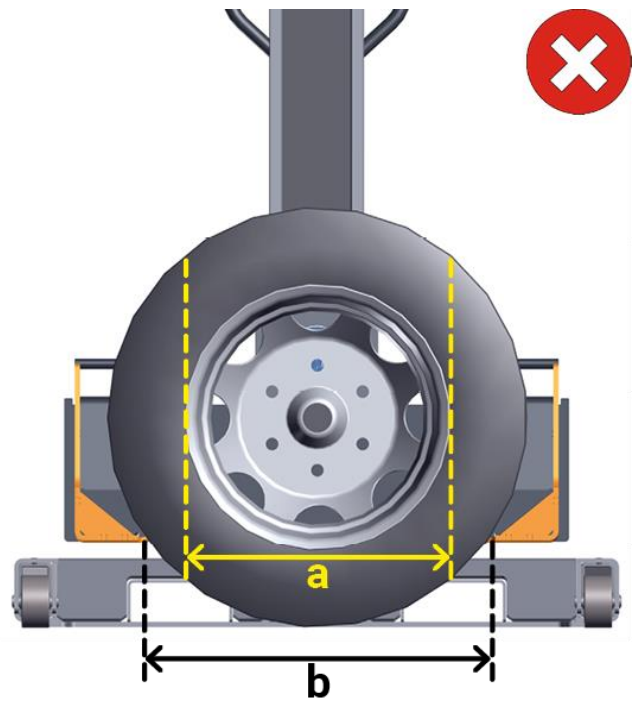

Wheel forks adjusted too far: $b > a$

3.3 Picking up a Vehicle



WARNING

Before lifting a vehicle, make absolutely sure that there are no objects under the contact surface of the lifting column. Danger of tipping!

Push the vehicle supports of the individual lifting columns all the way to the stop under the wheels or mounting points of the vehicle to be lifted.

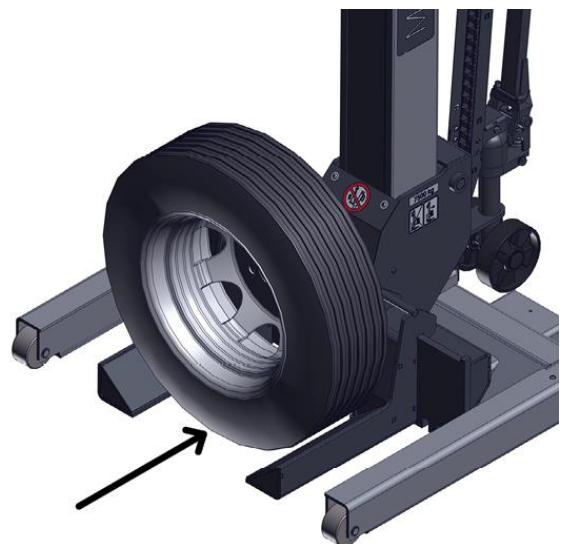

3.4 Controls and Indicators

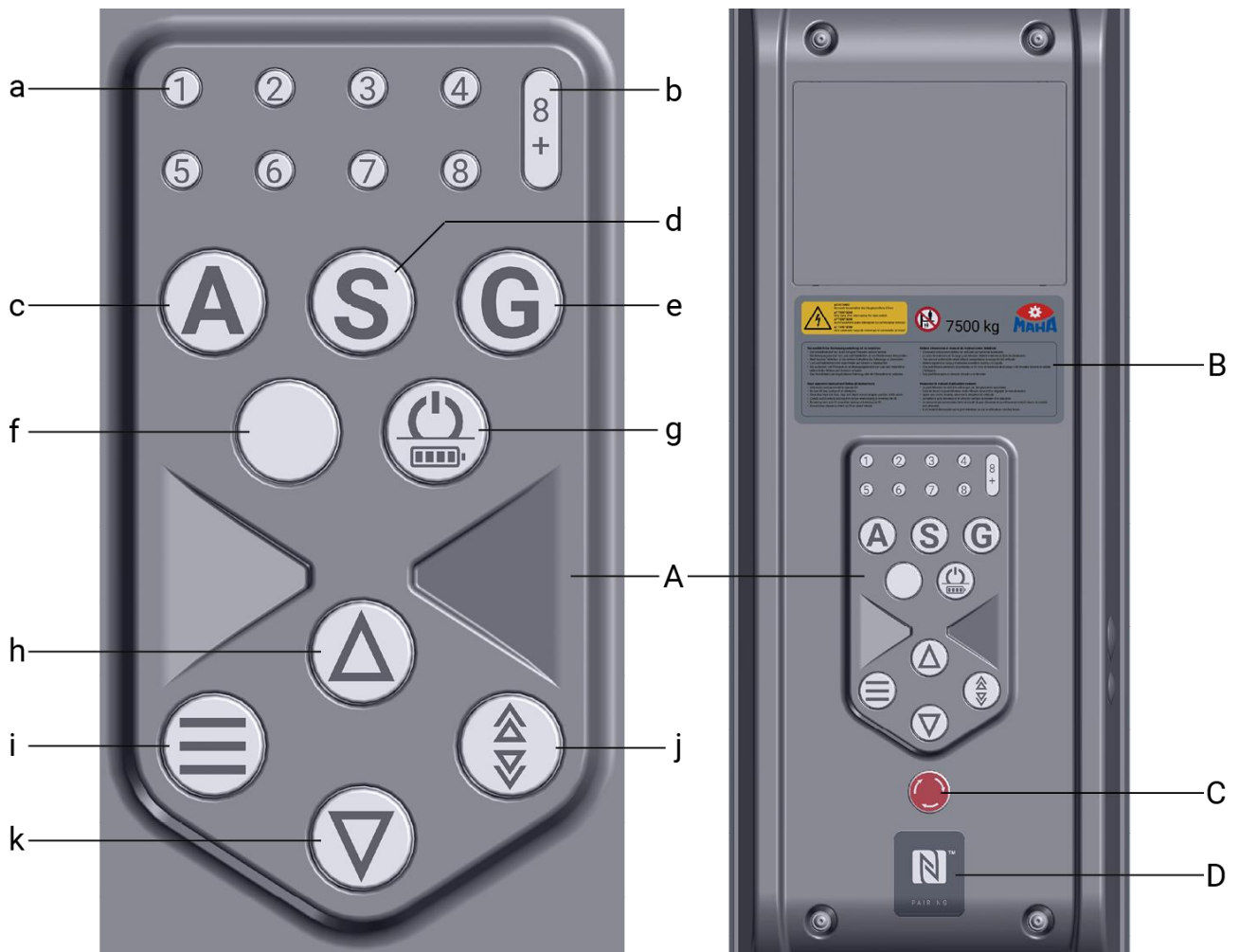

A Control panel

a Lifting column lamps 1...8

b Lifting column lamp 8+

c ALL button

d SINGLE button

e GROUP button

f ERROR lamp

g ON/OFF button

h UP button

i FUNC button

j SPEED button

k DOWN button

B Short operating instructions

C Emergency stop pushbutton

D NFC sensor field

3.5 Switching on

To switch on a column, press the ON/OFF button briefly. This is followed by a self-test during which all lamps light up briefly and the signal generator sounds briefly. The ON/OFF button lights up continuously.



If the lifting columns are switched on when the emergency stop button is pressed, an error code is output (see section "Troubleshooting > Error Codes").

3.6 Login Process (Pairing)



Pairing of the lifting columns via NFC tag and sensor field

3.6.1 Login Lifting Column

To put an individual lifting column into operation after switching it on, the NFC tag must be held against the sensor field twice at short intervals. After the first time, the signal generator sounds once briefly and the lifting column lamp 1 lights up. With repeated confirmation by the NFC tag, the beeper sounds again, the ALL button lights up and the UP and/or DOWN button lights up blue. The column is ready for operation.

3.6.2 Connect Lifting Columns to Form a Network

In order to connect the lifting columns into a network (min. 1 to max. 8 columns) after switching on, the selected columns must be preselected **once** in succession with the NFC tag after switching on.

To close the connection, the NFC tag is held once again against the sensor field of the last column added. The signal generator confirms this by beeping briefly twice. The network is now closed. To add another column to the network, the network must be opened and reassembled.

The lifting column lamps indicate which lifting columns are active by lighting up. The digits 1 to 8 are arranged in the order of pairing.



The first lifting column that has been paired is assigned the number 1, the second the number 2, and so on. It is therefore recommended that when pairing, the lifting columns are included in the network in sequence so that it is easy to identify which lifting column is in which position of the vehicle to be lifted.

IMPORTANT: It must be ensured that only the columns that are to be used on the vehicle are grouped together.

3.6.3 Cancel Login Process



WARNING

When not in use or **before** transferring to another vehicle, an existing network must be released by pressing the ON/OFF button!

During the login process, data is stored on the NFC tag and in the paired columns, which must be deleted when the login process is cancelled. It is essential to close the network first. Pressing and holding the ON/OFF button reopens the network and deletes the data in the paired lifting columns.

3.6.4 Error in a Column during Pairing

If there is an error in a lifting column, it cannot be included in a network. When trying to pair with the NFC tag, 5 beeps are emitted and pairing is denied. In order to be able to connect this lifting column, the error must first be rectified.

3.7 Lifting and Lowering

The UP or DOWN button is used to move the lift. If one or both buttons light up blue, you can move in the respective direction.



If both buttons are not illuminated, either the system cannot be moved at all or it is currently being operated from another lifting column. In the network, only one column can be operated at a time.

3.7.1 Driving up to an Obstacle

If an obstacle is unexpectedly encountered during lowering, the control system interrupts the lowering process.

The DOWN button is no longer lit and the UP button flashes briefly repeatedly. On the other lifting columns in the network, the DOWN button is also not illuminated and the UP button is continuously illuminated.

To free the carriage, it must be moved upwards until the DOWN buttons on all lifting columns light up again.

3.7.2 CE Stop

The CE stop is preset at the factory.

When lowering the lifting columns, the lowering movement is stopped as soon as one lifting carriage in the network has reached the CE stop height. At the same time, the beeper sounds once.

Pressing the DOWN button again causes the lifting carriages to move further

down. The signal generator sounds continuously while lowering as long as the column with the lowest lifting height is within the CE stop area.

3.8 Radio Standby

Radio standby is switched off on delivery.

If there is no action on the lift control for 5 minutes, the lifting column network switches to "Radio standby" mode and releases the radio channel used. Every 4 seconds, the lamps or control button lamps that were lit up until then flash briefly.

If a button of a column is pressed in Radio standby, the signal generator sounds as long as the button is pressed. To exit Radio standby, the ON/OFF button must be pressed briefly. Then the lamps flash quickly while the controller searches for a free radio channel. As soon as the lamps light up continuously, the lifting column network is ready for operation again.

3.9 ALL Operating Mode

In the ALL operating mode, the entire system, i.e. all lifting columns together, is always moved with the UP or DOWN button. All lifting column lamps of the columns in the network are permanently lit.



If the <A> button flashes on a column in the network, the network cannot be operated. Normally, there is then an error, or at least one lifting column is in SINGLE or GROUP operating mode.

3.10 SINGLE Operating Mode

To be able to move certain lifting columns of the closed system individually, e.g. to free a single wheel or to readjust it, the SINGLE operating mode can be activated on the desired lifting columns. Several lifting columns of a network can also be in SINGLE operating mode at the same time.



IMPORTANT: It must be ensured that the lifted load does not become unstable.

To activate the SINGLE operating mode on a column, press the SINGLE button <S>. The beeper sounds once. Then confirm the selection within 10 seconds with the NFC tag on the sensor field. The beeper sounds twice and the <S> button starts to light up. Now this lifting column can be moved UP or DOWN individually. All other lifting columns in the network can no longer be operated unless they are also in SINGLE operating mode.

If the SINGLE operating mode is not confirmed with the NFC tag within the 10-second time window, then the relevant column switches back to the last active operating mode.

To exit the SINGLE operating mode, press the ALL button <A>. At the same time, the beeper sounds once and the <A> button starts to light up.

If at least one lifting column of the network is in the error state, the operating mode cannot be changed to SINGLE. No movement is possible!

3.11 GROUP Operating Mode

A group can be formed in order to remove several lifting columns from a network and to be able to move them together, e.g. for the installation and removal of vehicle axles. A group consists of a minimum of one lifting column, in practice several lifting columns.



To do this, press the <G> GROUP button on the desired lifting column. The beeper sounds once. Afterwards, this selection must be confirmed within 10 seconds with an NFC tag. At the same time, the beeper sounds twice and the <G> button starts to light up. The GROUP operating mode is now activated on this lifting column.

If the changeover is not confirmed with the NFC tag, then the previously active operating mode is restored.

To integrate further lifting columns into this group, repeat the same procedure on the desired lifting columns of the same network.

While the GROUP operating mode is active, the overall network cannot be moved. If at least one lifting column of this network is in SINGLE operating mode, the group cannot be moved either.

In GROUP operating mode, only the lifting column lamps of the lifting columns that are in the group are lit. All other lifting column lamps flash.

If all lamps of the lifting columns in the group are flashing, then one or more lifting columns are in the SINGLE operating mode.

Deactivate group mode or remove lifting columns from the group:

Press ALL button <A>, the beeper sounds once. This lifting column is thus excluded from the group.

To exit the GROUP operating mode, all associated lifting columns must be excluded from the group in the same way. As soon as all lifting columns are back in ALL operating mode, the entire system can be moved again.

3.12 Fast Travel (SPEED)

The SPEED button can be used to move the lifting column network or individual lifting columns at a higher speed. To activate fast travel, the SPEED button must be held down while pressing the UP or DOWN button at the same time. This is also possible during the travel movement. The SPEED button starts to light up.



If the SPEED button is released during the process, the process continues at normal speed.

The travel speed when fast travel is activated depends on the loading condition of the lifting column.

Fast travel can be terminated by releasing the SPEED button or the UP/DOWN buttons.

Fast travel is not possible if

- the lifting column is not yet referenced;
- no weight is known at the beginning of the lowering process.

3.13 Switch off / Open Network

The lifting column is switched off by pressing the ON/OFF button for longer than 4 seconds. When switching off, all lamps go out and a possibly existing network is released.



When switching on again, the network must be re-paired and closed.

While the charging cables are connected, the lifting columns cannot be switched off, or they switch on again automatically immediately.

The lifting column control is switched off in two stages:

Stage 1 – After approx. 2 seconds, an existing network is opened.

Stage 2 – After another approx. 1.5 seconds, the lifting column control is switched off completely.

If the lifting columns are to be paired again, release the ON/OFF button after releasing the pair and start pairing.

When the network is open, all lifting columns switch off automatically after approx. 10 minutes if no charging cable is connected.

3.14 Radio Communication

Radio communication is the default communication interface and is automatically activated when the network is closed, unless a cable network has been formed.

Radio communication can be disturbed by radio transmitters that transmit in the similar frequency range, such as WiFi or other lifting column networks. If this is the case, a new free radio channel can be searched for manually (see section “Search New Radio Channel”) or a cable link can be established (see section “Cable Emergency Operation”).

If a radio interruption is detected, the error "Radio connection" is output. At the same time, the error lamp flashes the error code "Radio error". The green lifting column lamps start to flash. The lifting column number with the slowly flashing lamp is the lifting column that has detected the error. The fast flashing lamps indicate the lifting column numbers to which the communication of this lifting column is disturbed.

While the "Radio error" code is output, the lifting column control unit attempts to find a free radio channel at intervals of approx. 20 seconds. The signal generator always sounds briefly to indicate that a new radio channel is currently being tested. If a suitable radio channel has been found, it is automatically set on all lifting column controls and the error is then deleted.

Continued operation of the lifting column is possible again as soon as a suitable radio channel has been found. Otherwise, it is recommended to establish a new interconnection with the cable emergency operation.

If the battery is discharged or there is a defect, this lifting column cannot be reintegrated into the network. The network must then be opened at all lifting columns and a new network formed.

3.15 Search New Radio Channel

If radio problems occur frequently, radio communication can be improved by searching for a new, free radio channel. To do this, press the SINGLE <S> button for 3 seconds.



Afterwards, the best available radio channel is searched for in the course of approx. 20 seconds and automatically set at all lifting columns of this network. During this time, the illuminated operating buttons flash as in Radio standby. As soon as a new radio channel is set, all operating buttons light up. Moving the lifting columns is now possible again.

3.15.1 Communication Error (Radio or Cable Error)

If columns are interconnected, the preferred communication among columns is radio.

In the lifting column controllers that detect a communication error (radio or cable error), the lifting column lamps of those lifting columns whose data are faulty or missing flash rapidly.

For controllers that detect an error on another lifting column, all lifting column lamps flash.

For the lifting column with the error (except for radio or cable error), the associated lifting column number flashes.

If there is a radio or cable error, all lifting column lamps of the affected lifting columns flash rapidly. In case of other errors, only the lamp with the assigned number flashes on the lifting column where the error occurred.

3.15.2 Overview: Status of the Lifting Column Lamps

Status	Description
	Lifting column is not active/not in the network.
Dark	In the case of the lifting column with the error, only the associated lifting column number is illuminated, all other lifting column numbers are dark. Error lamp flashes. Exception: Communication error; here the lifting column numbers with the communication errors flash quickly.
Lights	Lifting column is active. Lifting column can be moved.
Flashes slowly every second	Lifting column has been paired and is waiting for the network to be closed. Lifting column with error (error lamp also flashes).
Flashes quickly at 0.5-second intervals	Lifting column cannot be moved because SINGLE or GROUP operating mode is active. Communication channel of the lifting column with error or defect. Communication can be via cable or radio.

3.16 Cable Emergency Operation

Cable emergency operation is to be used if, for example, there is a poor radio connection with radio interruptions.

Only one cable group can be formed at a time with the same charging cable connection.

When creating additional cable networks, each must have its own charging cable connection.

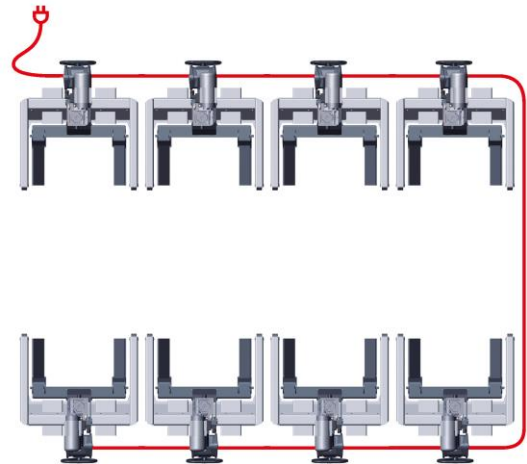

3.16.1 Activate Cable Emergency Operation

The following steps must be performed in the specified order to activate the cable emergency mode:

- 1 Open the existing network with the ON/OFF button.
 - 2 Switch off all lifting columns of the cable network to be created with the ON/OFF button.
 - 3 Connect all lifting columns of the cable network to be created with the charging cable.
 - 4 Switch on all lifting columns of the cable network to be created with the ON/OFF button.
 - 5 Perform pairing process with the NFC tag.
 - 6 Close the cable network with the NFC tag.
- The lifting columns are ready for operation.

3.16.2 End Cable Emergency Operation

The following steps must be performed in the specified order to end the cable emergency operation:

- 1 Open the existing cable network with the ON/OFF button.
 - 2 Switch off all lifting columns of the cable network with the ON/OFF button.
 - 3 Remove all charging cables.
- The lifting columns are ready to set up a new radio-controlled network.

3.17 Output Software Version Identifier

If the ON/OFF button is pressed for a long time when the lifting column is switched on, a flash code is output which can be used to identify the installed software version. After switching on, the beeper sounds 4 times and the error lamp is switched on.



After that, the ON/OFF button starts to output the flash code in blue. When the ON/OFF button is released, the output of the flash code is also stopped and the self-test of the lamps starts.

To output the flash code again, the lifting column must first be switched off. Then proceed again as described above.

3.18 Charge Battery

NOTICE

Early charging – when the lamp colour changes from green to yellow - can extend the battery life.

The lamp colour of the ON/OFF button indicates the current battery charge level.



GREEN

Battery has enough capacity.



YELLOW

Few lifting cycles possible, charging recommended.



RED

Battery must be charged.

The discharge process is not abrupt, but is noticeable by a gradual slowing down of the lifting and lowering movements.

When the battery is discharged, an error code is issued. To acknowledge the error, the emergency stop pushbutton must be actuated and unlocked again. In this situation, the lifting columns can only be lowered.

For charging, the lifting columns must be connected to the mains supply by means of charging cables. When connected, the lifting columns are automatically switched on. During charging or as long as the mains supply is connected, the lamp of the ON/OFF button flashes and the lifting column cannot be switched off.

Procedure:

- 1 Connect the first lifting column to the mains supply via charging cable.
 - 2 Connect the second lifting column to the first lifting column via charging cable.
 - 3 Connect all other lifting columns *one after the other* via charging cable.
- The battery of the respective lifting column is fully charged when the lamp of the ON/OFF button lights up green continuously.

4 Troubleshooting

If an error occurs, the error lamp lights up or flashes. It is then no longer possible to move the lifting column network or the lifting column.

The number of flash cycles of the error lamp gives the error code (see section "Error Codes").

By pressing the FUNC button, the flash code output in progress can be terminated and immediately started from the beginning. This enables fast counting of the flash code without unnecessary waiting time.



4.1 Diagnostics

- a. Is only one number lamp of the network flashing on the lifting column?
 - ▶ This is the lifting column with the operating error.
- b. Are all the number lamps of the network flashing on the lifting column?
 - ▶ The error has occurred on another lifting column. The error lamp flashes once, indicating that the error has occurred on another lifting column. There is no error on the lifting column in question, but it cannot be moved because another lifting column has an error.
- c. Are number lamps (one or more) of the network flashing rapidly?
 - ▶ Communication error (radio, cable). The number lamps from which faulty data sets are received or which do not send any data sets flash quickly.

4.2 Error Codes

Flash code	NFC code	Description	Subcode	Remedy
1	E001	Error on other lifting column		Search for faulty lifting column.
2	E002	Emergency stop actuated		Unlock emergency stop, press several times.
3	E003	Radio error	1 = Radio protocol 2 = Radio module	Establish cable connection.
4	E004	Cable connection error		Check cable and plug connections.
5	E005	Sluggish movement; motor power too high		Reduce load, lubricate recirculating ball nut.
6	E006	Battery discharged/undervoltage		Charge batteries.
7	E007	Motor temperature too high, line to temperature sensor interrupted		Wait until motor has cooled down. Contact service team.
8	E008	Height difference too large		In SINGLE operating mode, align the lifting column.

Flash code	NFC code	Description	Subcode	Remedy
9	E009	Output stage overcurrent/short circuit		Contact service team.
10	E010	Speed sensor	1 = Short circuit 2 = Cable break	Contact service team.
11	E011	Sensor lifting column bottom	1 = Short circuit 2 = Cable break	Contact service team.
12	E012	Safety switch	1 = Short circuit 2 = Cable break	Contact service team.
13	E013	Load pickup sensor	1 = Short circuit 2 = Cable break	Contact service team.
14	E014	Nut break		Contact service team.
15	E015	Latch	1 = Current too high 2 = Current too low	Contact service team.
16	E016	Motor brake	1 = Current too high 2 = Current too low	Contact service team.
17	E017	Brake chopper		Contact service team.
18	E018	Spindle or motor speed out of tolerance		Contact service team.
19	E019	Overvoltage in the DC link		Contact service team.
20	E020	Voltage 12 V		Contact service team.
21	E021	Keypad error		A button is pressed when switching on or closing the network. Check, contact service.

5 CE Declaration of Conformity

See following page(s).



Original EC Declaration of Conformity

CE492501-en



MAHA Maschinenbau Haldenwang GmbH & Co. KG

herewith declares as a manufacturer its sole responsibility to ensure that the product named hereafter meets the safety and health regulations both in design and construction required by the directives stated below.

This declaration becomes void if any change is made to the product that was not approved by named company beforehand.

Model

C_RGA 7.5 UC
C_RGA 8.5 UC

VP Number

VP 451191 | VP 451193 | VP 451195
VP 451196 | VP 451197

Designation

Mobile Column Lift

Directives

2006/42/EC
2014/30/EU

Standards

DIN EN 1493:2023-04
DIN EN 60204-1:2019-06

Person Authorised to Compile the Technical File

Ralf Kerkmeier

MAHA Maschinenbau Haldenwang GmbH & Co. KG, Hoyen 20, 87490 Haldenwang, Germany

Haldenwang, 2024-03-01

Dr. Peter Geigle
Managing Director

Control PCB RGA NG 1 wireless

Material N° 1417026



Japanese Radio Law (電波法) compliance:

The device MAH RGA FM 1 V1.2 is granted pursuant to the Japanese Radio Law (電波法). This device should not be modified (otherwise the granted designation number will become invalid).



MAHA Maschinenbau Haldenwang GmbH & Co. KG · Hoyen 20 · 87490 Haldenwang · Germany
☎ +49 8374 585-0 · ✉ maha@maha.de · 🌐 www.maha.de